

Assembly Manual



McFARLANE

UNIVERSAL TILLAGE

INCITE™ 5000 SERIES

Ensures accurate seed depth, even emergence, and better yields.



MADE IN THE USA 

Read and understand the manual. This manual provides information and procedures to safely assemble the INCITE™ 5000.



Version: 10906 — Serial Number 19412 and Up

Contents

INTRODUCTION	4
Contact Information	4
SAFETY	4
General	4
Safety Alert Symbols	5
Safety Icons Nomenclature	6
Personal Protection/Important Information	6
Prohibited Actions	6
Hazard Avoidance	6
General Assembly Safety	7
GENERAL INFORMATION	8
Component Locations	8
BOLT TORQUE CHART	10
Tire and Lug Torque Specifications	10
ASSEMBLY PROCEDURE	11
Attach the Lift Arms and Outer Lights	12
Attach the Inner Lights and SMV Sign	13
Attach the Harrow Sections to the Lift Arms	14
Attach the Rolling Baskets	14
Lubrication Points	16
Layout Diagram for IC-5014	17
Layout Diagram for IC-5020	18
Layout Diagram for IC-5027	19
Layout Diagram for IC-5032	20
Layout Diagram for IC-5040	21

Introduction

Thank you for purchasing the McFarlane Incite™ Universal Tillage™ System. We know that you will get many years of dependable service because McFarlane has been manufacturing quality agricultural equipment since 1936.

With its unique ability to run in different field types, spring or fall, the Incite™ has one-of-a-kind adjustability not found anywhere else on the market. This new tool has the flexibility to adjust to different soils and different crop types going from corn to wheat with ease, saving time and money.

Contact Information

If you have questions not answered in this manual, require additional copies, or the manual is damaged, please contact your local dealer or:

McFarlane Mfg. Co., Inc.
1330 Dallas Street
P.O. Box 100
Sauk City, WI 53583

Phone: (608) 643-3321

Toll Free: (800) 627-8569

Fax: (608) 643-3976

E-mail: info@flexharrow.com

Web: www.flexharrow.com

Safety

General

Safety of the operator and bystanders is one of the main concerns in designing and developing a new piece of equipment. Designers and manufacturers build in as many safety features as possible. However, every year many accidents occur which could have been avoided by a few seconds of thought and a more careful approach to handling equipment.

Most work-related accidents are caused by failure to observe basic safety rules or precautions. An accident can often be avoided by recognizing potentially hazardous situations before an accident occurs. As you assemble, operate, tow, or maintain the Incite™ (unit), you must be alert to potential hazards. You should also have the necessary training, skills, and tools to perform any assembly procedure.

Improper operation and maintenance of this unit could result in a dangerous situation that could cause injury or death.

WARNING



Do not use or tow the unit until you read and understand the information contained in this manual.



Safety precautions and warnings are provided in this manual and on the unit. If these hazard warnings are not heeded, bodily injury or death could occur to you or to other persons.

McFarlane cannot anticipate every possible circumstance that might involve a potential hazard. The warnings in this manual and on the product are, therefore, not all-inclusive. If a method of operation not specifically recommended by us is used, you must satisfy yourself that it is safe for you and for others. You should also ensure that the unit will not be damaged or be made unsafe by the methods that you choose.

The information, specifications, and illustrations in this manual are based on the information that was available at the time this material was written and are subject to change without notice.

Also refer to the Incite™ Operation and Parts Manual for additional safety instructions.



Safety Alert Symbols



This is the safety alert symbol. It is used to alert you to potential personal injury hazards. Obey all safety messages that follow this symbol to avoid possible injury or death.

This manual contains DANGERS, SAFETY INSTRUCTIONS, CAUTIONS, IMPORTANT NOTICES, and NOTES which must be followed to prevent the possibility of improper service, damage to the equipment, personal injury, or death. The following key words call the readers attention to potential hazards.

Hazards are identified by the “Safety Alert Symbol” and followed by a signal word such as “DANGER”, “WARNING”, or “CAUTION”.

⚠ DANGER

Indicates an imminently hazardous situation which, if not avoided, will result in death or serious injury. This signal word is limited to the most extreme situations.

⚠ WARNING

Indicates a potentially hazardous situation which, if not avoided, could result in death or serious injury.

⚠ CAUTION

Indicates a potentially hazardous situation which, if not avoided, may result in minor or moderate injury.

NOTICE

Indicates that equipment or property damage can result if instructions are not followed.

SAFETY INSTRUCTIONS









Safety instructions (or equivalent) signs indicate specific safety-related instructions or procedures.

Note: Contains additional information important to a procedure.

Safety Icons Nomenclature

This manual and the equipment has numerous safety icons. These safety icons provide important operating instructions which alert you to potential personal injury hazards.











Personal Protection/Important Information

-  Read the manual
-  Eye protection
-  Hand protection
-  Inspect equipment
-  Use proper tools
-  Warning decal alert
-  Head protection
-  Protective shoes
-  Stop engine
-  Remove key
-  Set parking brake
-  Transport lock
-  Weight Rating

Prohibited Actions

-  No children
-  No alcohol
-  No drugs
-  No riders

Hazard Avoidance

-    Crushing hazard
-  Crushing hazard (Foot)
-  Falling hazard
-  Safety alert symbol
-  Sharp object hazard
-  Zero pressure
-  High-pressure fluid hazard
-  Lifting device attachment

General Assembly Safety

WARNING



Read And Understand Manual

To prevent personal injury or even death, be sure you read and understand all of the instructions in this manual and other related OEM equipment manuals! This equipment is dangerous to children and persons unfamiliar with its operation. The operator should be a responsible adult familiar with farm machinery and trained in this equipment's operations. Do not allow persons to operate or assemble this unit until they have read this manual and have developed a thorough understanding of the safety precautions and how it works.

This unit was designed for a specific application; DO NOT modify or use this unit for any application other than that for which it was designed.

Units operated improperly or by untrained personnel can be dangerous!



Rolling Over Hazard

When disconnecting the unit or leaving the operator's seat:

1. Stop the tractor or towing vehicle.
2. Shut off the engine and remove the ignition key.
3. Set the brakes.
4. Make sure the wheel cylinder transport locks are attached.
5. Relieve hydraulic fluid pressure.
6. If parking the unit, make sure the jack stand is lowered and the retaining pin is installed.



Injury Hazard

Do not permit children to play on or around the stored unit.

Personal Protection Equipment

When working around or operating this unit, wear appropriate personal protective equipment. This list includes but is not limited to:



- A hard hat
- Protective shoes with slip resistant soles
- Protective goggles, glasses, or face shield
- Heavy gloves and protective clothing





Impaired Operator Hazard

Do not attempt to operate this equipment under the influence of drugs or alcohol.

Review the safety instructions with all users annually.

WARNING

High-Pressure Fluids

1.  Check or tighten all connections BEFORE pressurizing system.
2.  Relieve all pressure before removing hoses and/or valves by:
 - a. Stopping the engine.
 - b. Holding the control levers in float or neutral position.
3.  DO NOT use your bare hand to check for potential leaks. Always use a board or cardboard when checking for a leak.

Escaping hydraulic fluid under pressure, even a pinhole size leak, can penetrate body tissue, causing serious injury and possible death. If fluid is injected into your skin, it must be treated immediately by a doctor familiar with this type of injury.



Personal Injury Hazard

Do not use this unit if it is in need of repair. If you believe the condition of this unit could cause damage, injury, or death, you should immediately stop using the unit and fix the problem.



Fall Hazard

Do not use the unit as a platform. Do not stand on top of the unit at any time. Do not ride on the unit or allow others to ride on it.

SAFETY INSTRUCTIONS



Replace any missing or hard-to-read decals.

Decal placement and part numbers can be found in the Nomenclature section of the Operator's manual.



Visually inspect the unit for any loose bolts, worn parts, or cracked welds, and make necessary repairs.

To prevent injury, use a tractor equipped with a Roll Over Protective System (ROPS).

General Information

Component Locations

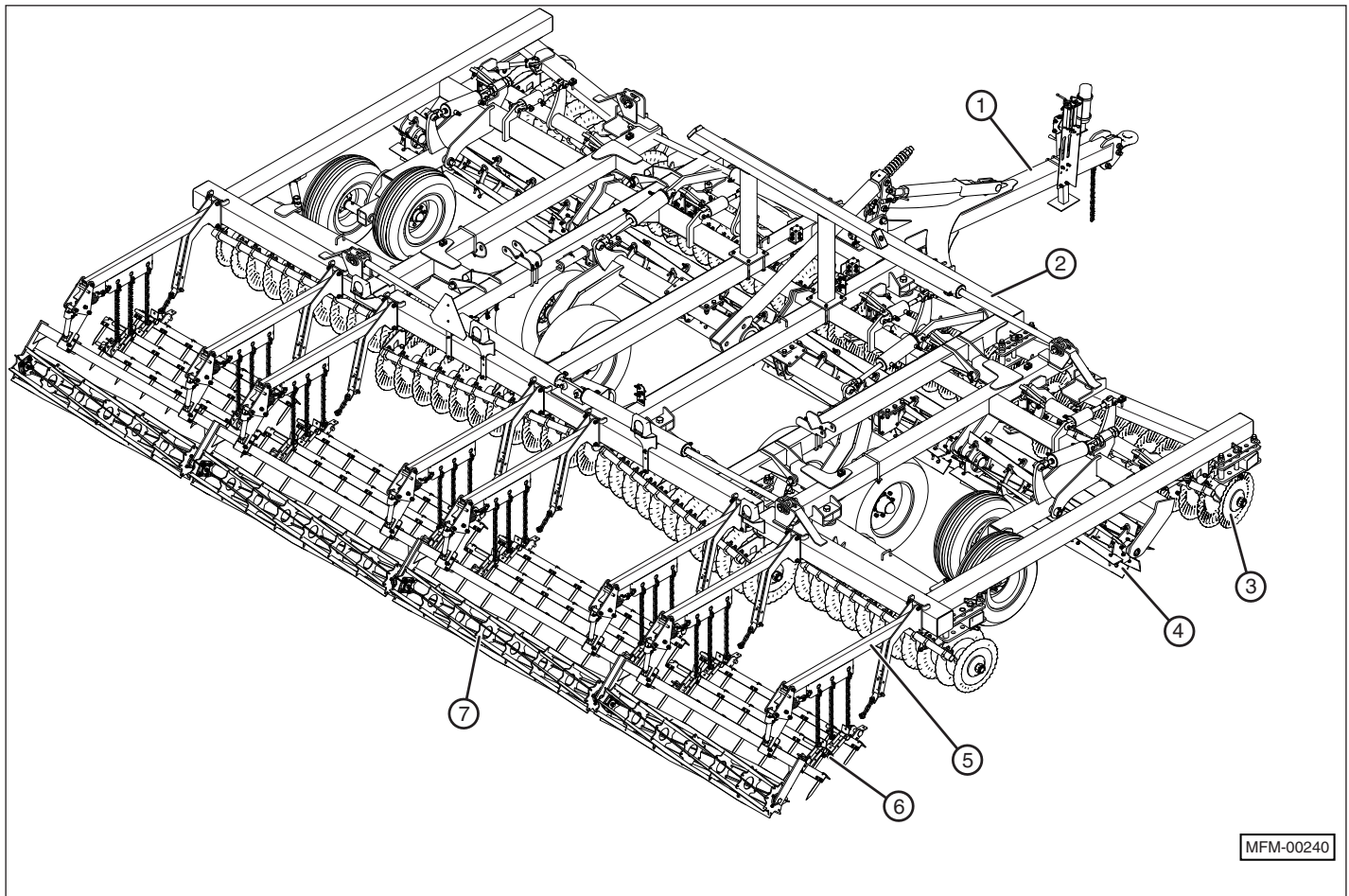

- (1) Hitch Frame. (2) Main Frame. (3) Disk Gangs.
- (4) Spiral Reels. (5) Lift Arms. (6) Harrow Sections.
- (7) Rolling Baskets.

1. Hitch Frame



2. Main Frame



5. Lift Arms



3. Disk Gangs



6. Harrow Sections





4. Spiral Reels



7. Rolling Baskets



Bolt Torque Chart

Bolt Head Markings	 No Marking		 3 Radial Lines		 6 Radial Lines	
	SAE Grade 2 N·m (ft-lbs)		SAE Grade 5 N·m (ft-lbs)		SAE Grade 8 N·m (ft-lbs)	
1/4"	8	(6)	12	(9)	17	(12)
5/16"	13	(10)	25	(19)	36	(27)
3/8"	27	(20)	45	(33)	63	(45)
7/16"	41	(30)	72	(53)	100	(75)
1/2"	61	(45)	110	(80)	155	(115)
9/16"	95	(70)	155	(115)	220	(165)
5/8"	128	(95)	215	(160)	305	(220)
3/4"	225	(165)	390	(290)	540	(400)
7/8"	230	(170)	570	(420)	880	(650)
1"	345	(225)	850	(630)	1320	(970)

Tire and Lug Torque Specifications

Model	Tire Size	Ply Rating	Tire Pressure	Lug Size	Lug Torque (lb.ft.)		Tire and Wheel Weight
					Min	Max	
IC-5014	12.5L-15	10 ply	44 psi	9/16"	80	90	40
IC-5020	FS24 340/60R16.5	—	73 psi	9/16"	80	90	89
IC-5027	FS24 380/60R16.5	—	73 psi	5/8"	85	100	95
IC-5032	FS24 380/60R16.5	—	73 psi	5/8"	85	100	95
IC-5040	FS24 380/60R16.5	—	73 psi	5/8"	85	100	95
WING FRAME	11L-15	8 Ply	36 psi	1/2"	75	85	33

Assembly Procedure

Note: Some photos in this section may look slightly different than the product being assembled.

1. Follow all safety instructions in this and/or other related manuals.
2. Make sure all the required parts have been received.

WARNING



Lifting Hazard

Before lifting any component, make sure the lifting capacity of the overhead lifting device exceeds the weight of the component being lifted. An inadequate lifting capacity can cause the load to fall, resulting in component damage, personal injury, and possibly death.



Crush Hazard

Do not stand beside or under any components suspended from an overhead lifting device.

Personal injury and possibly death can occur by being crushed from a heavy component.



Crush Hazard

The tongue weight of the unit can be up to 1450 lbs. (658 kg). Use care when lifting or attaching the unit to the tractor. Never place any part of your body under the tongue or hitch assembly.

3. Using a suitable lifting device, attach the Hitch Assembly to the Main Frame using two 1-1/2" x 9-1/2" pins (1). Secure the pins into place with two 9/16" x 3-1/2" grade 8 bolts and locking nuts.

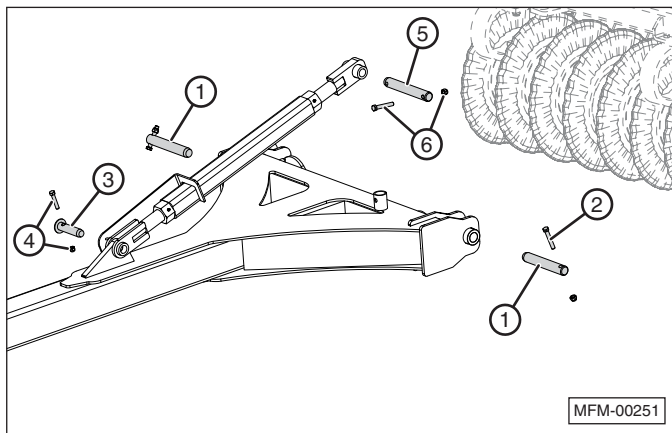

4. Assemble the adjustable Hitch Turnbuckle to the hitch using the 1-1/4 x 5-1/4" headed pin (3), and secure with a 1/2 x 2-3/4" grade 8 bolt and locking nut (4).

5. Attach the upper end of the adjustable Hitch Turnbuckle to the Level Lift pivot plates using 1-1/4 x 10" pin (5), and secure with a 1/2 x 2-3/4" grade 8 bolt and locking nut (6).
6. Attach the Hydraulic Hose Rack (7) to the Hitch using 1/2" X 6" X 5" U-Bolts (8) and 1/2" locking nuts (9).

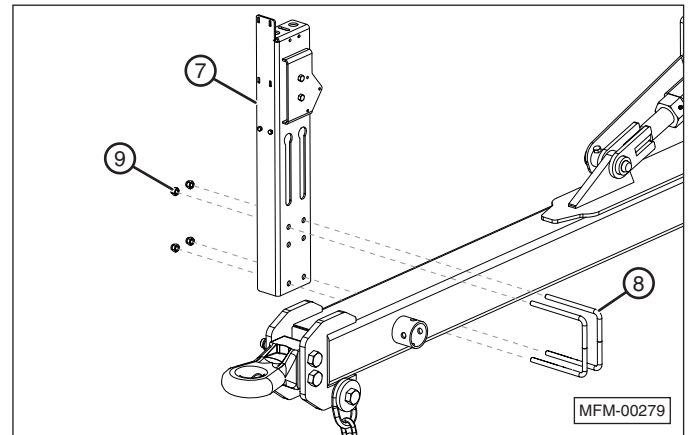

7. Route the hydraulic hoses through the Hydraulic Hose Rack Clamp (10), and secure to the Hydraulic Hose Rack (11) using 7/16" x 2" hex bolts and locking nuts.

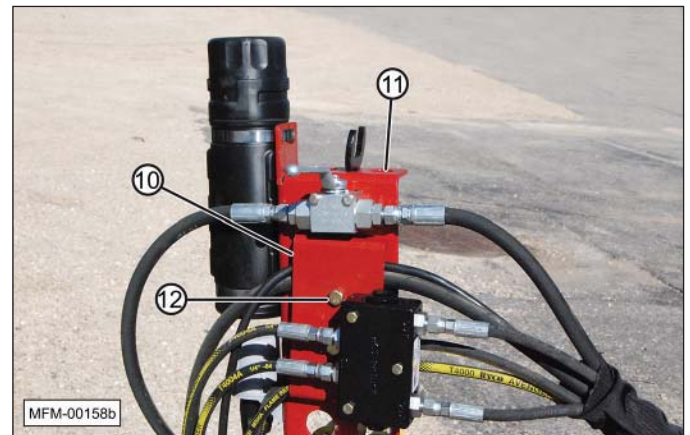

8. Attach Light Plug Storage Bracket (13) to Hydraulic Hose Rack (11) using the 1/4" x 1" hex bolts, lock washers, and hex nuts.

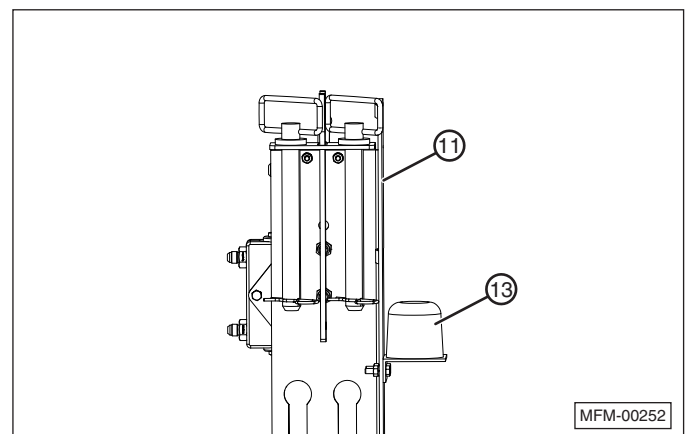

- Place Wing Lock Pins (14) with #6 Bridge Pins (15), and Turnbuckle Wrench (16) into the Hydraulic Hose Rack.

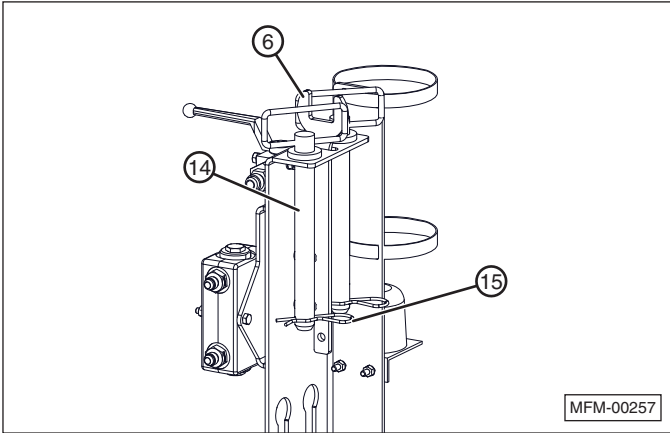

- Attach Document Tube (17) to Hydraulic Hose Rack (11) using Hose Clamps (18).

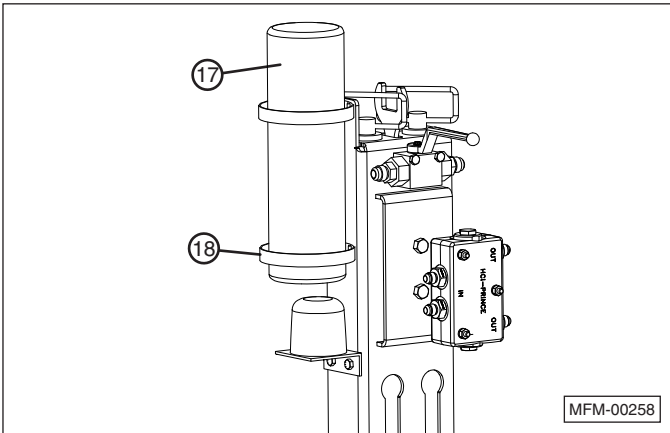

- If it is not already attached, attach Jack (19) to the Hitch Assembly, in either the support position or the storage location.

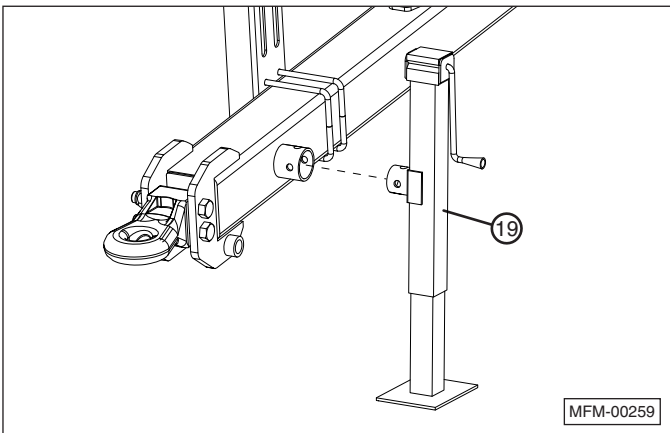

Attach the Lift Arms and Outer Lights

- Remove the Lift Arms from their shipping pallets.



- Bolt the Lift Arms to the main frame using 5/8-11 x 2" bolts, lock washers, and 5/8" nuts. Use the layout diagrams in this manual to properly configure the attachment of the Lift Arms to the frame.

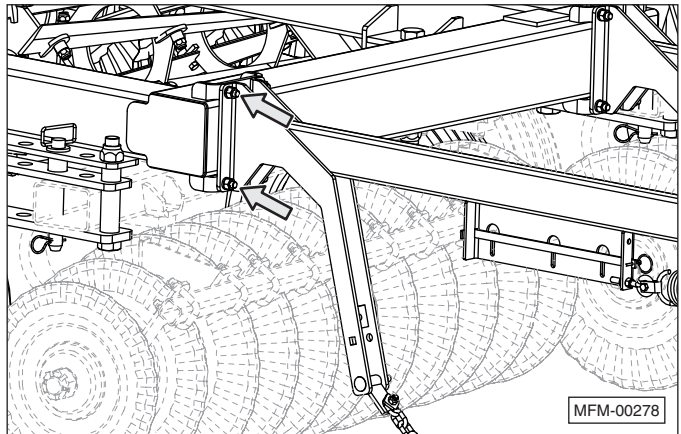

- Assemble and attach the two outer Amber Lights to the main frame using the 5/8-11 x 2" bolts, lock washers, and nuts that attach the outer Lift Arms.

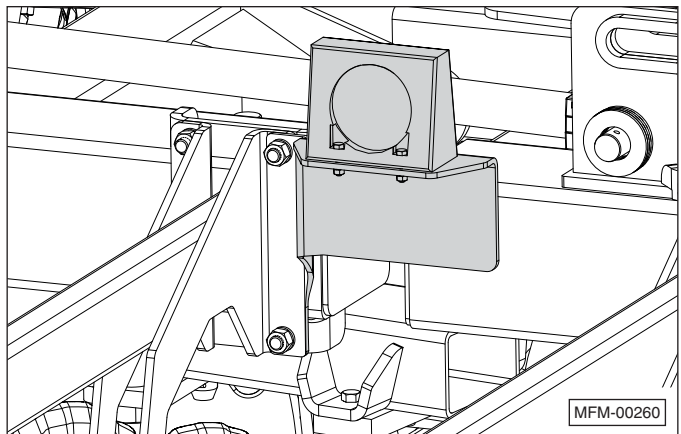

4. Install the amber decals on the outside surface of both main frame outer lift arms. The decals are located 6-1/4 inches forward of the rear end of the lift arms and 1/2 inch below the top of the tube.

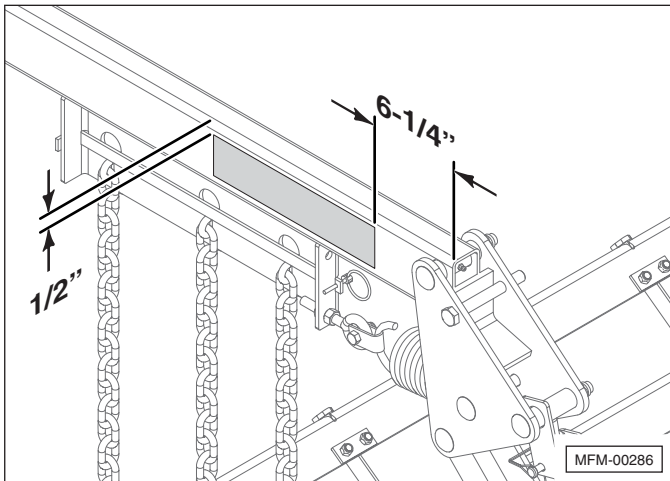
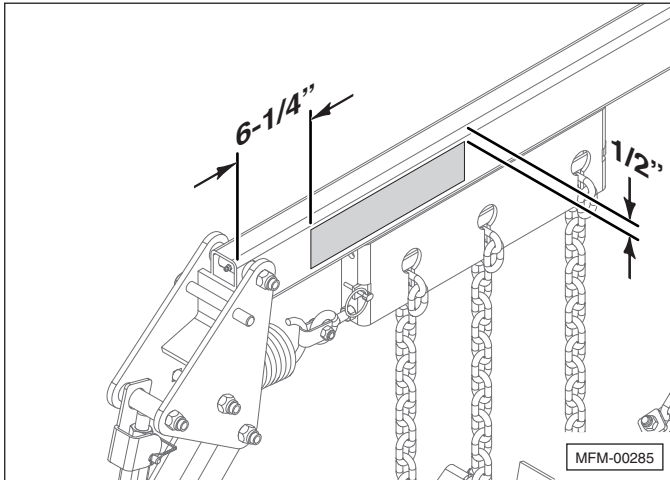

Attach the Inner Lights and SMV Sign

1. Attach the inner Red Lights using 1/2" x 7" x 8-1/4" U-bolts and 1/2" lock nuts. Tighten the nuts completely.

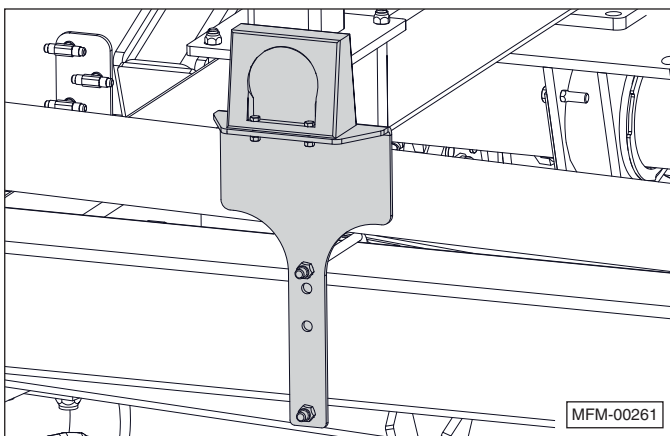

Note: The Red Lights must be positioned at least 2', but not more than 5' from the centerline of the unit.

2. Attach the SMV sign using a 3/8" x 7" x 8" U-bolt and two 3/8" lock nuts. Tighten the nuts completely.



3. Remove the plastic cable tie and extend the wiring harness wire to the back of the frame.

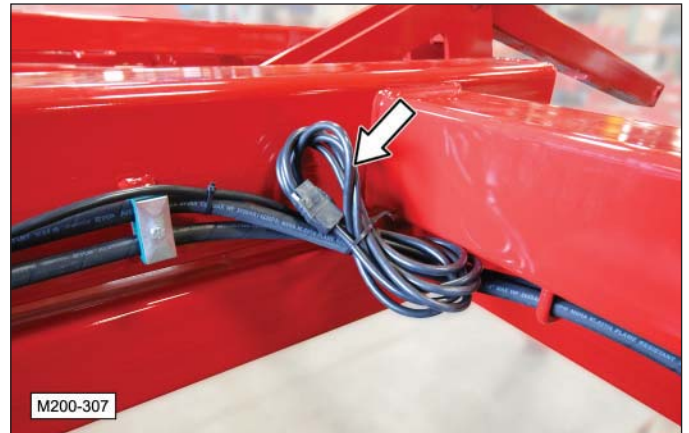

4. Plug one end of wishbone wiring harness (1) into main wiring harness (2). Plug the other ends into each light assembly.

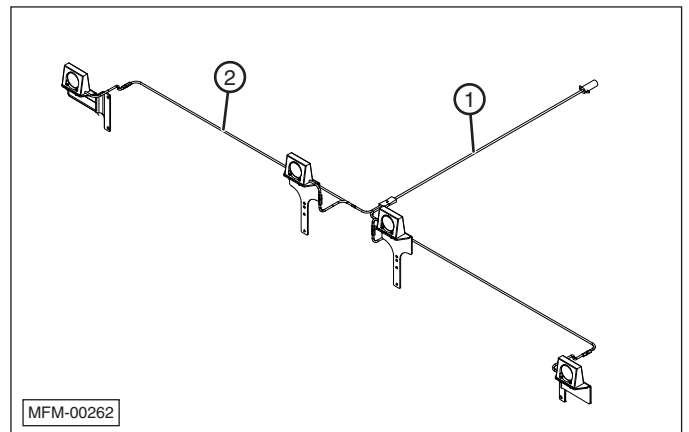

5. Secure the wiring harness to the frame using plastic cable ties.

Attach the Harrow Sections to the Lift Arms

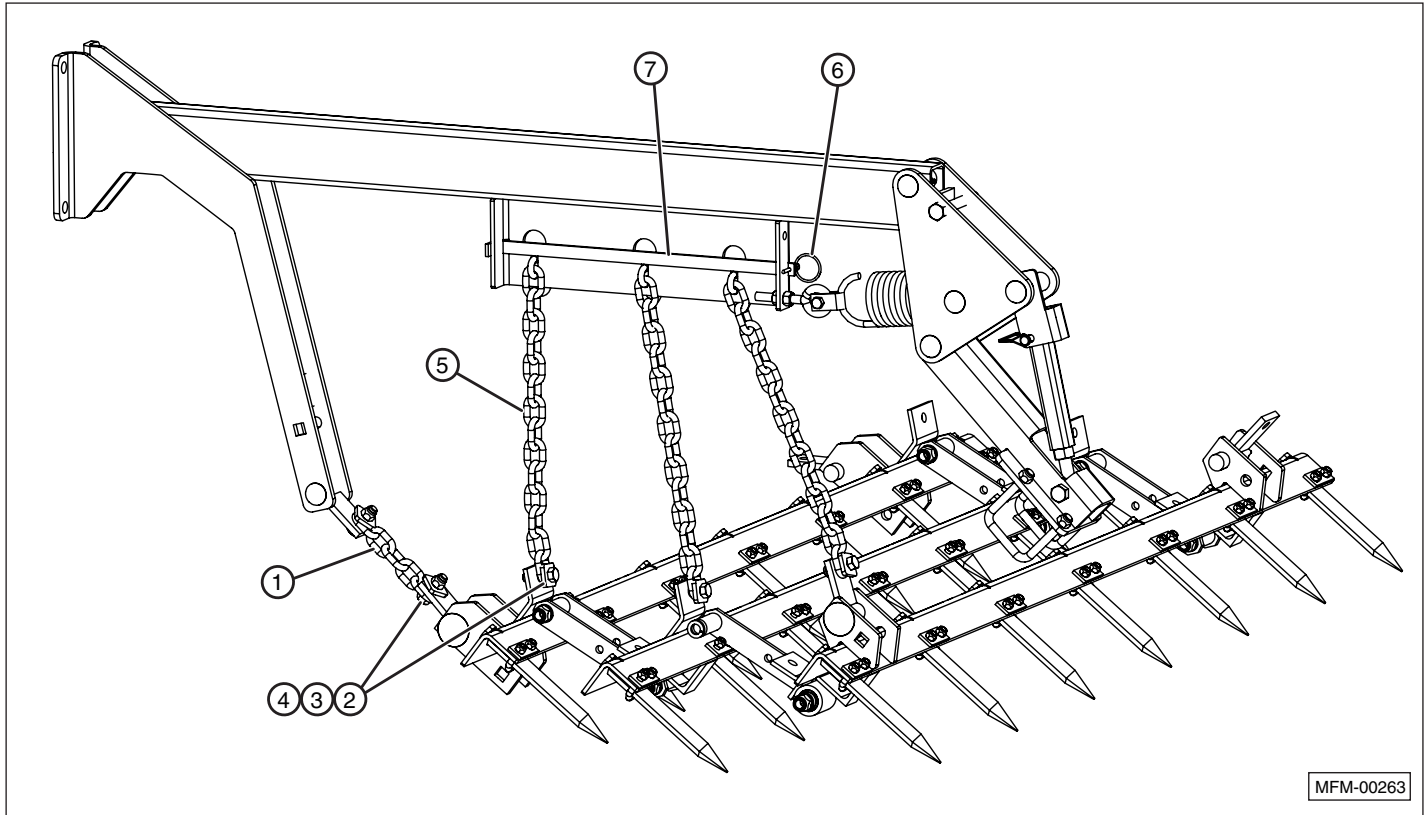

1. Attach the front of the Harrow Sections to the Lift Arm Pull Point using Five Link Pull Chain (1), 1/2" x 1-3/4" grade 5 Hex Bolt (2), Flat Washer (3), and 1/2" Locking Nut (4).
2. Attach the Harrow Sections to Sixteen Link Lift Chain (5), using 1/2" x 1-3/4" grade 5 Hex Bolt (2), Flat Washer (3), and 1/2" Locking Nut (4).
3. Attach the Harrow Sections to the Lift Arms by removing locking bar retainer clip (6) and locking bar (7). Insert Sixteen Link Lift Chain (5) into the slot. Make sure the chains are not twisted when inserting into the slot. Replace the locking bars and retainer clips.

Attach the Rolling Baskets

1. Remove the Rolling Baskets from their shipping pallets.



2. Bolt the Rolling Baskets to the Lift Arms using 5/8-11 x 5" bolts, clamp plates, and 5/8" locknuts. Use the layout diagrams in this manual to properly configure the attachment of the Rolling Baskets to the Lift Arms.

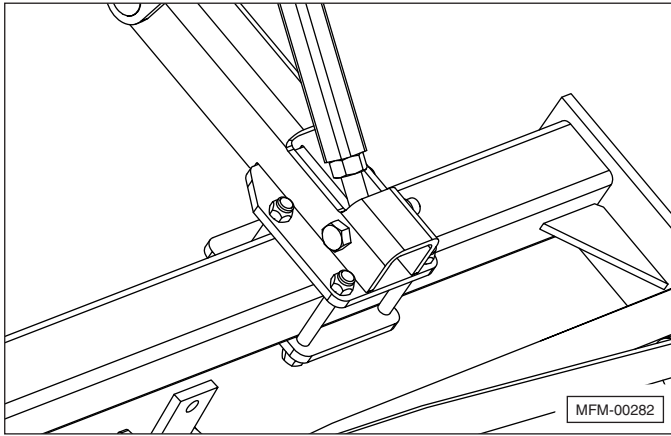

3. Maintain a 1" to 1-1/2" space between adjacent Rolling Basket Assembly end plates at the center of the machine.

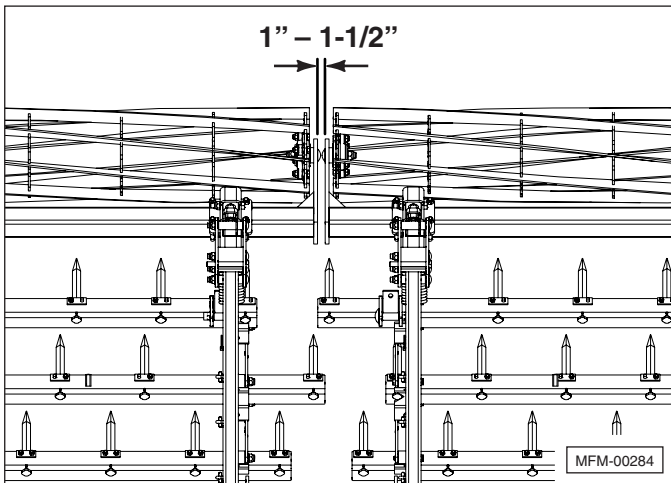

4. Maintain a 3" space between adjacent Rolling Basket Assembly end plates at the wing fold locations.

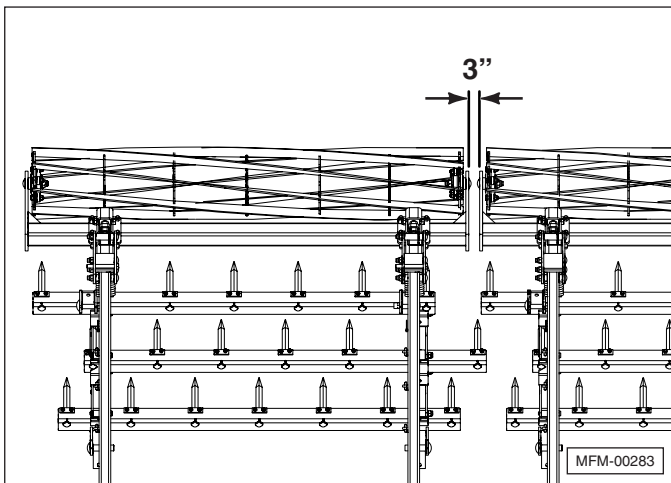

5. Add grease to the locations shown in the illustration on the following page. Refer to the Operator's Manual for additional information on periodically greasing the unit.

NOTICE

Wheel bearings do not require lubrication during the initial assembly of the unit. These bearings should be greased sparingly every 50 hours of service. Check for end play in the bearings prior to adding grease.

6. When greasing a pin and bushing, add grease until it is visibly forced out of the joint.
7. Refer to the Operator's manual for an initial setup procedure.

This completes the assembly of your unit. Before using the unit, make sure that all components have been assembled properly, and that all fasteners are tight. If there are any questions regarding any of the setup instructions, contact your local dealer for an explanation. For information on proper operation, maintenance, troubleshooting, adjustment, bolt torque specifications, parts lists, layouts, etc., please refer to the Operators Manual document located in the Manual Storage Tube mounted on the Hydraulic Hose Rack. Do not operate this or any equipment unless you are sure that all components operate as they were designed to operate.

Lubrication Points

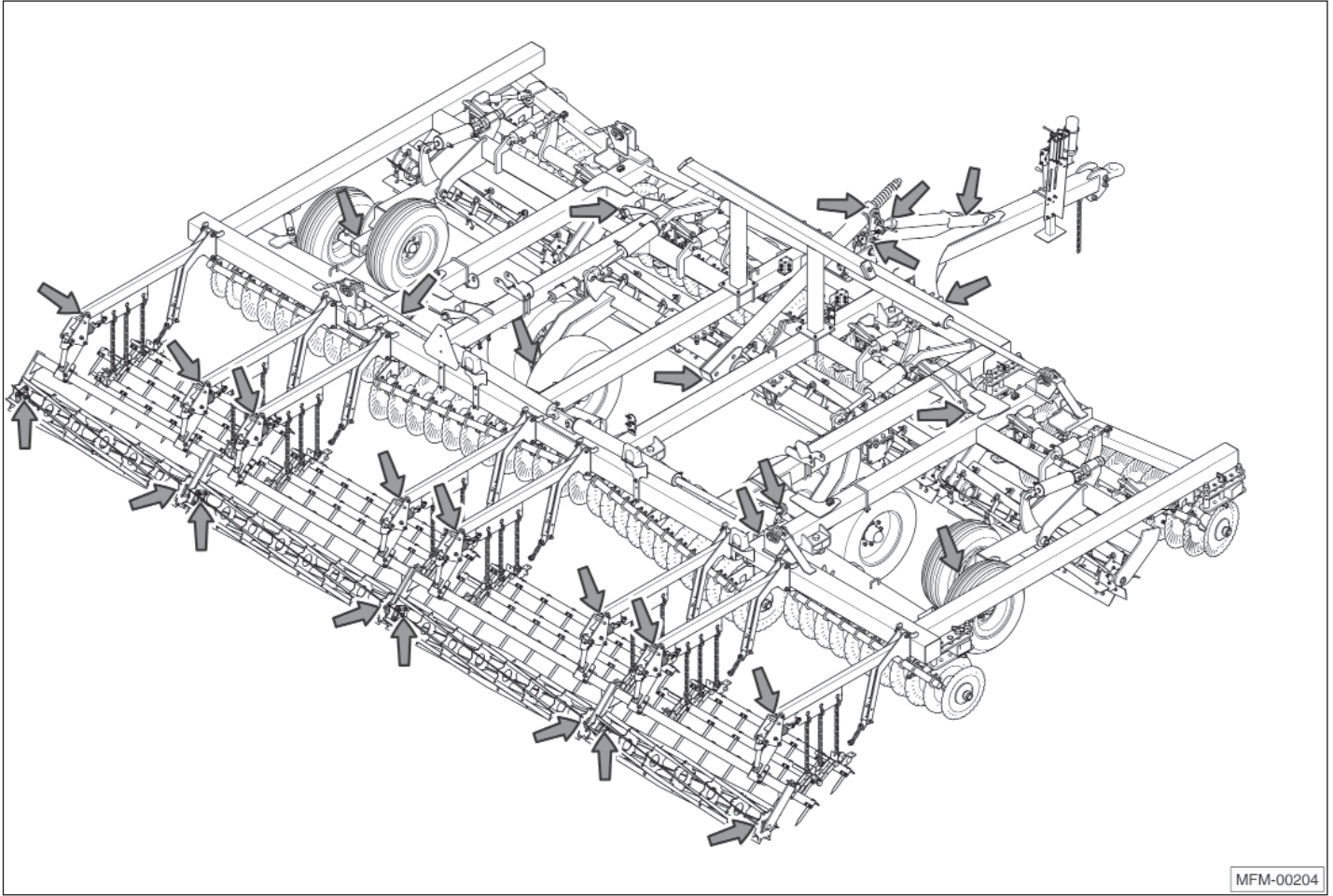

Layout Diagram for IC-5014

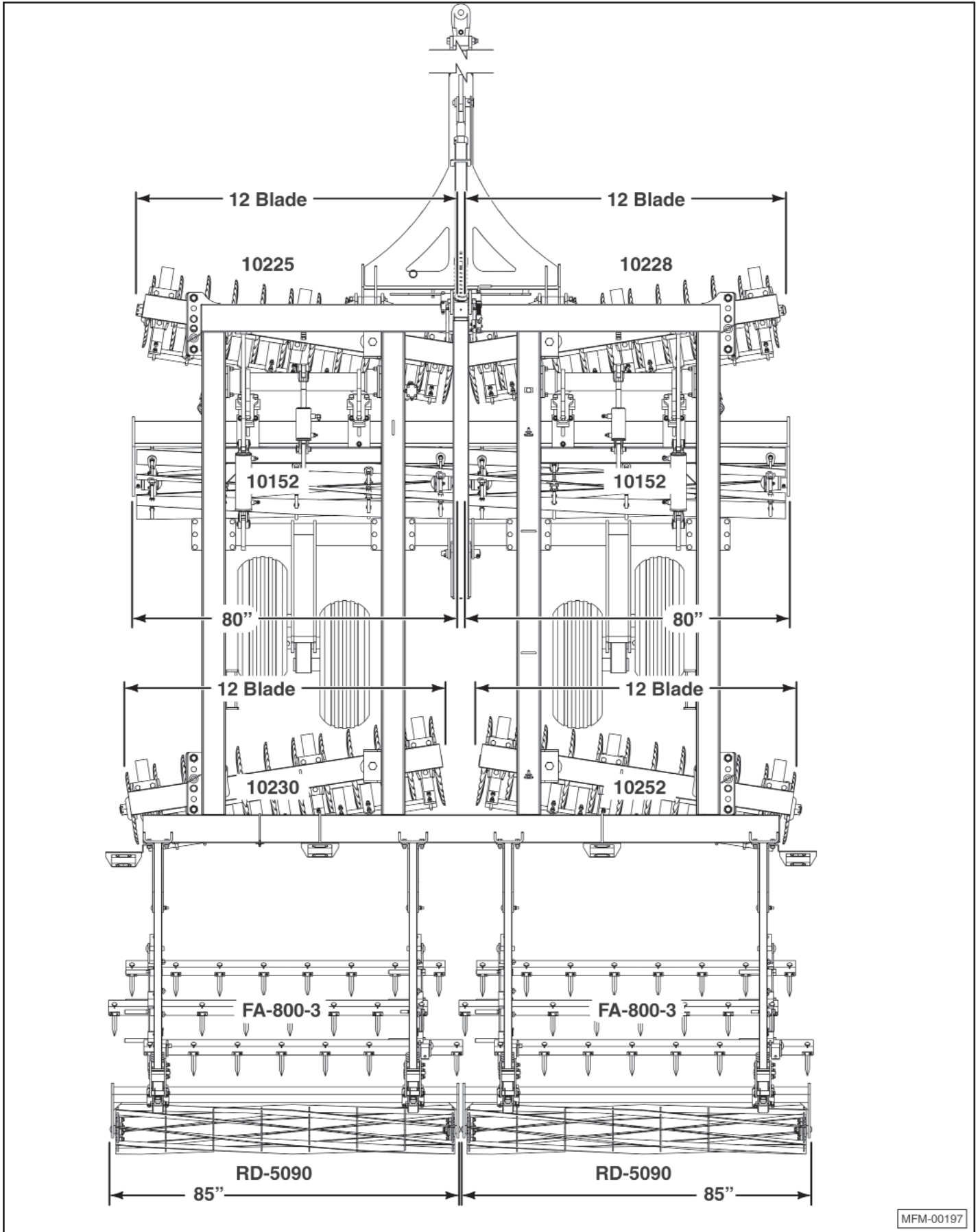

Layout Diagram for IC-5020

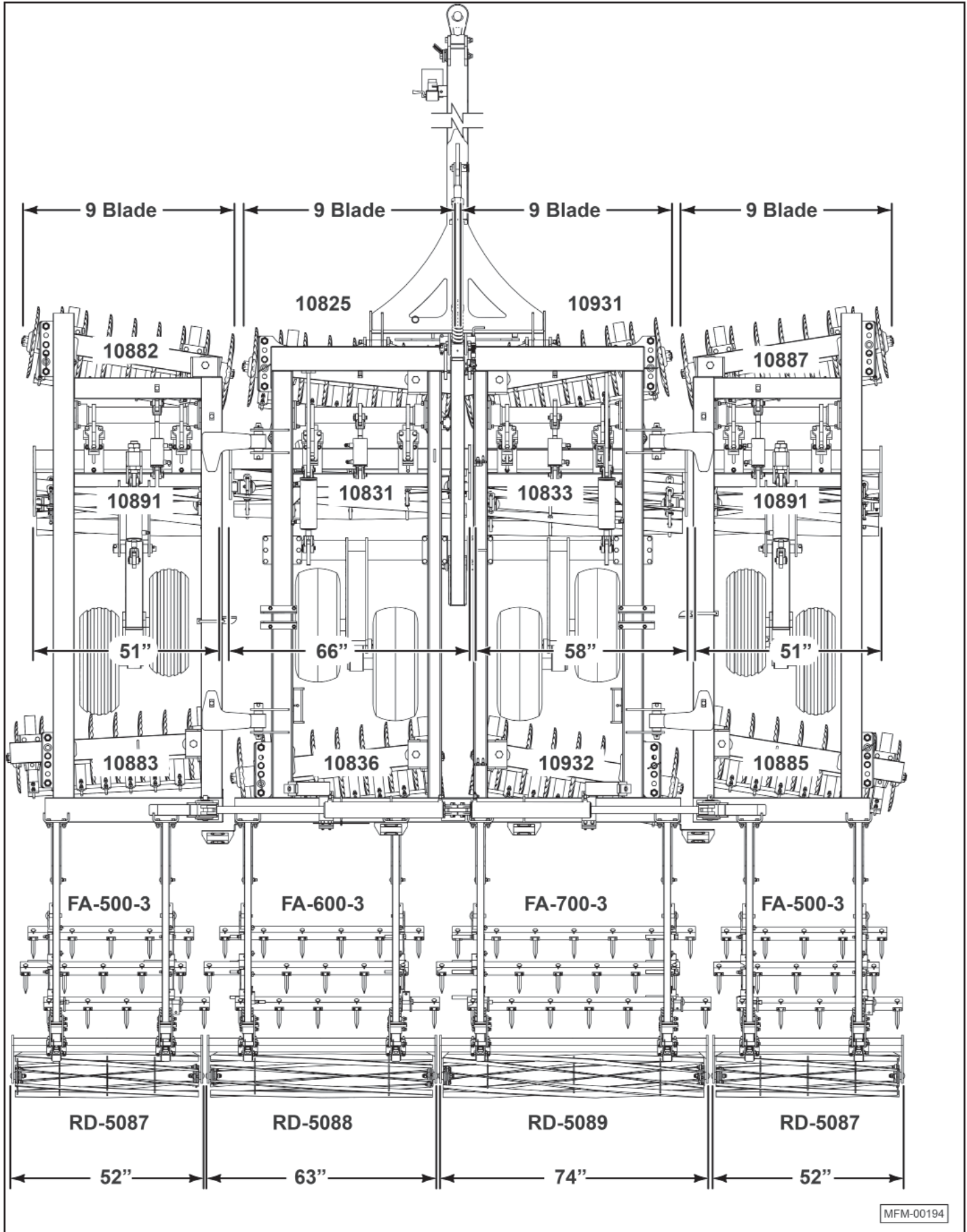

Layout Diagram for IC-5027

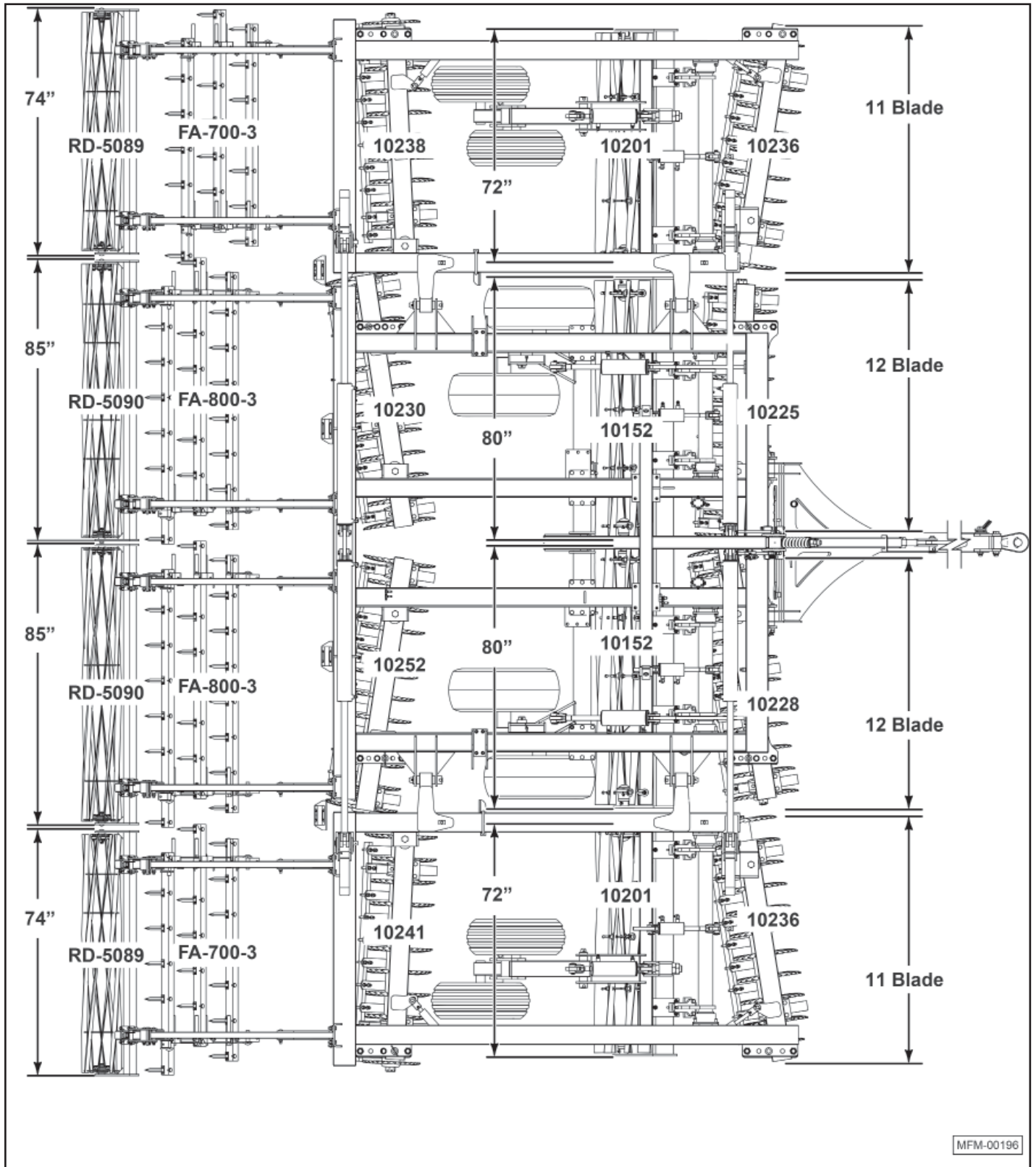

Layout Diagram for IC-5032

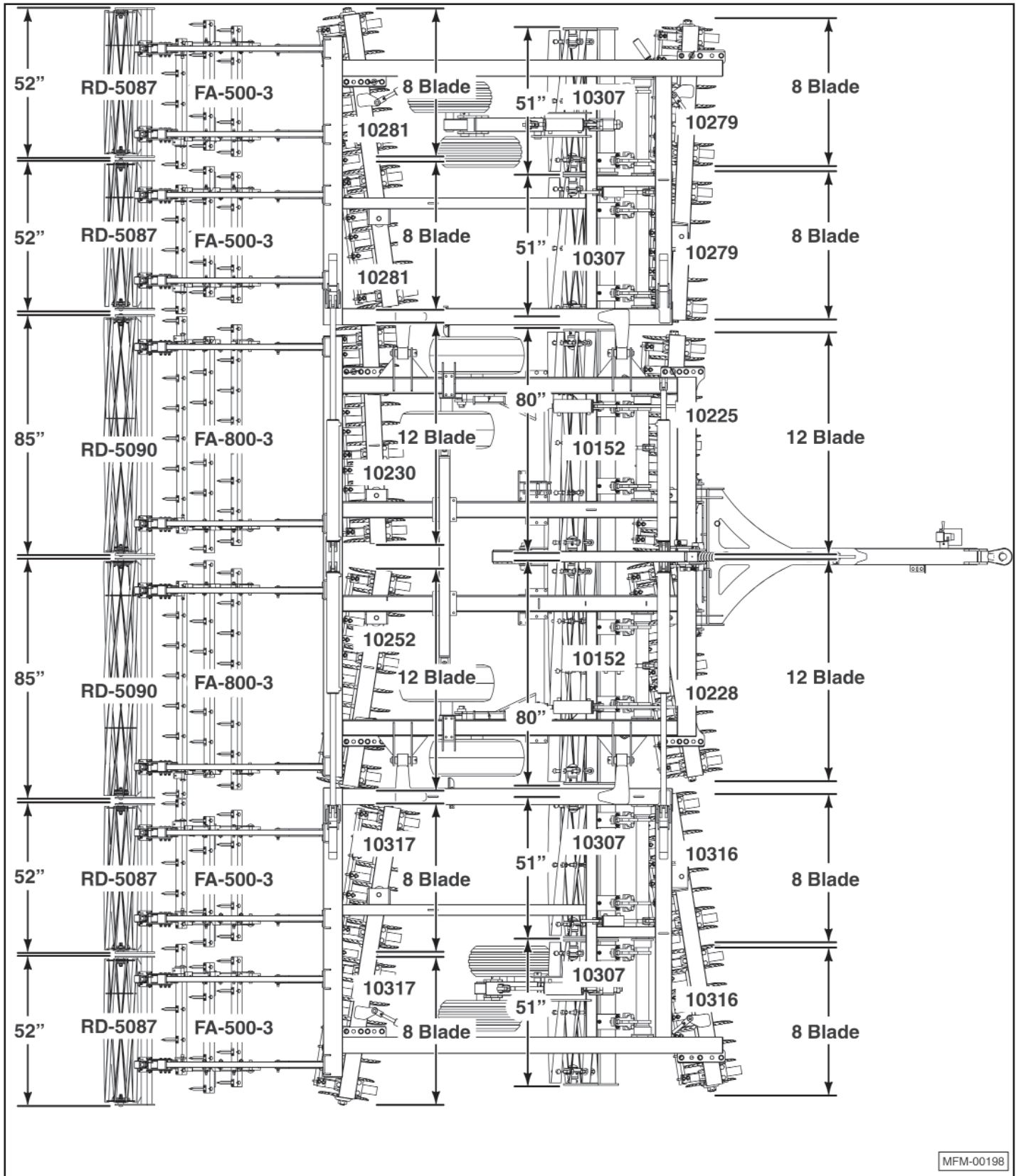

Layout Diagram for IC-5040

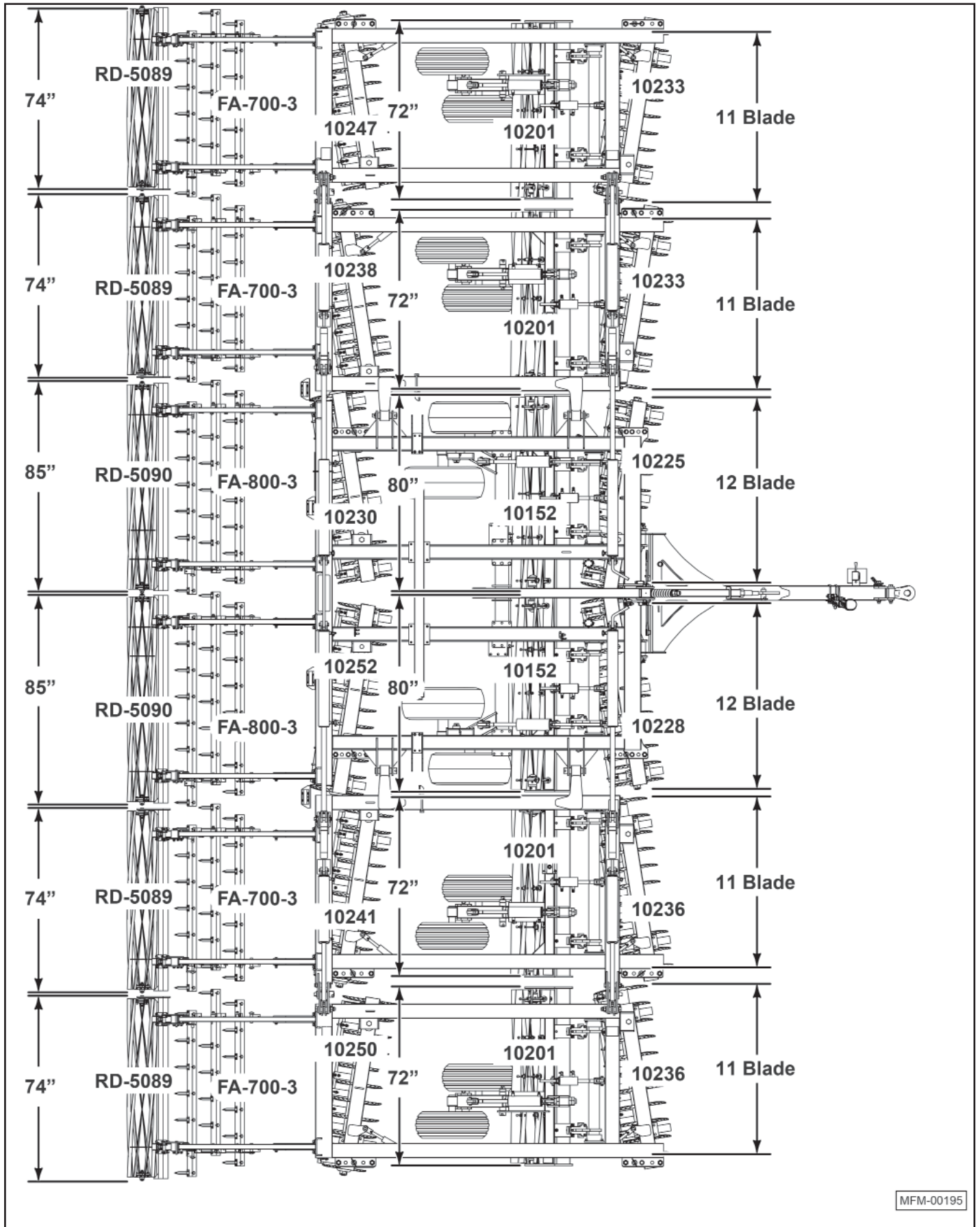

MFM-00195

Notes

Member of



**1330 DALLAS STREET, P.O. BOX 100
SAUK CITY, WISCONSIN 53583
PHONE: (608) 643-3321
TOLL FREE: (800) 627-8569
FAX: (608) 643-3976
WEB: www.flexharrow.com**